



杰美康机电
JUST MOTION CONTROL

2HSS86H-N

Hybrid stepper servo driver

user's manual



Tel: 0755-26509689 26502268

fax: 0755-26509289

E-mail: oversea@jmc-motion.com

Http: [//www.szjmc.com](http://www.szjmc.com)

**Address: Jiayu Science and Technology Park, Jin'an Road, Matian Street,
Guangming New District, Shenzhen**

Directory

1.Summary	- 4 -
2.Characteristic	- 4 -
3.Port Description	- 5 -
3.1 Alarm and in place signal output port	- 5 -
3.2 Brake signal output port	- 6 -
3.3 Control signal input port	- 7 -
3.4 Encoder feedback signal input port	- 8 -
3.5 Power port	- 9 -
4.Technical Indext	- 11 -
5.Control signal wiring	- 13 -
5.1 Control signal single ended common anode wiring-	13 -
5.2 Control signal single ended common cathode wiring-	14 -
5.4 232 serial communication wiring diagram	- 16 -
5.5 Control signal timing diagram	- 16 -
6.Function dial and subdivision dial switch settings	- 18 -
6.1 SW1 single and double pulse selection	- 18 -
6.2 SW2 logic direction setting	- 18 -
6.3 SW3-SW6 Subdivision Settings	- 18 -
6.4 SW7 instruction smoothing setting	- 19 -
6.5 SW8 open/closed loop mode selection	- 19 -
7.Error alarm and LED flashing frequency	- 20 -
8.Installation dimensions	- 22 -

9.Wiring diagram	- 23 -
10.Parameter settings	- 24 -
11.Common problems and troubleshooting	- 32 -
11.1 The power light is not on	- 32 -
11.2 Power on with red light warning	- 32 -
11.3 After running and rotating for a small angle, the red light will light up and give an alarm	- 32 -
11.4 Does not rotate after pulse input	- 33 -

1. Summary

The 2HSS86H-N hybrid stepper servo drive system perfectly integrates servo control technology in digital stepper drive. The product adopts an optical encoder, which samples position feedback at high speed every 50 microseconds. Once there is a deviation in the position, the position deviation can be immediately corrected. This product is compatible with the dual advantages of stepper technology and servo technology, and has the characteristics of low heat generation, low vibration, and fast acceleration. It is a highly cost-effective motion control product.

2.Characteristic

- ◆ No missing steps, precise positioning
- ◆ 100% rated torque drive motor
- ◆ Variable current control technology with high current efficiency
- ◆ Low vibration, smooth low-speed operation
- ◆ The open loop mode can be selected by dialing the code, and it can work normally without connecting the encoder
- ◆ The open loop mode can be selected by dialing the

code, and it can work normally without connecting the encoder

- ◆ Single and double pulses can be selected through dialing
- ◆ Built in acceleration and deceleration control to improve start stop smoothness
- ◆ Users can customize segmentation
- ◆ Compatible with 1000 and 2500 line encoders
- ◆ General application parameters do not require adjustment
- ◆ Over current protection, over voltage protection, over differential protection
- ◆ Green light indicates operation, red light indicates protection or offline

3.Port Description

3.1 Alarm and in place signal output port

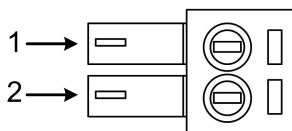

terminal	Symbols	Name	Explanation

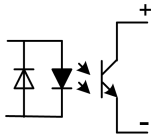
number			
1	ALM+	Alarm output positive	
2	ALM-	Alarm output negative	
3	PEND+	In place output positive	
4	PEND-	In place output negative	

3.2 Brake signal output port

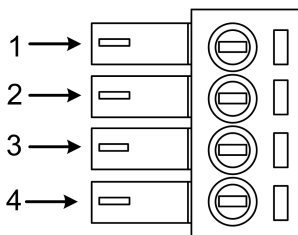

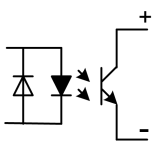
terminal number	Symbols	Name	Explanation
1	BREAK+	Brake output positive	
2	BREAK-	Negative brake output	

Note: The output signal of the brake control is an open collector output, and users need to connect an external 24V and relay to drive the brake (our company can provide a brake drive plate).

3.3 Control signal input port

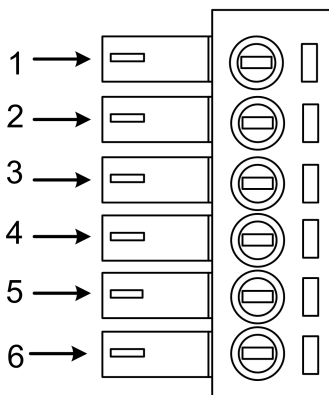

Terminal number	Symbols	Name	Explanation
1	PLS+	Pulse input positive	Compatible with 5V and 24V signals
2	PLS-	Pulse input negative	
3	DIR+	Direction input positive	Compatible with 5V and 24V signals
4	DIR-	Direction input negative	

5	ENA+	Enable input positive	Compatible with 5V and 24V signals
6	ENA-	Enable input negative	

3.4 Encoder feedback signal input port

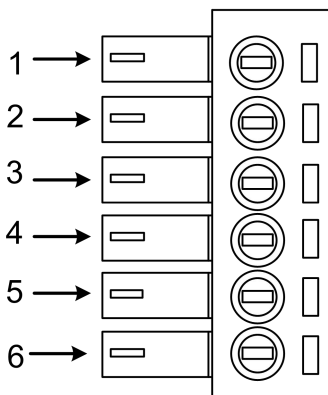

Terminal number	Symbols	Name	Wiring color
1	PB+	Encoder B phase input positive	Blue
2	PB-	Encoder B phase input negative	White
3	PA+	Encoder A-phase input positive	Yellow
4	PA-	Encoder A-phase input negative	Green
5	VCC	Encoder power supply	Red

		positive	
6	GND	Encoder power supply ground	Black

3.5 Power port

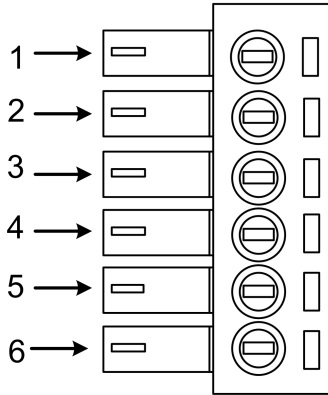

Terminal number	Identifying	Symbols	Name	Explanation
1	Motor phase line	A+	Motor A+end (red)	Motor A-phase winding
2		A-	Motor A-end (blue)	
3		B+	Motor B+end (green)	Motor B-phase winding
4		B-	Motor B-end (black)	
5	Source Input end	AC1	Power AC1	30-110VDC 24-75VAC

6		AC2	Power AC2	
---	--	-----	-----------	--

4. Technical Index

INPUT VOLTAGE		30-110VDC 24-75VAC
Continuing current		4.5A 20KHz PWM
Maximum pulse frequency		200K
Default Communication rate		57.6Kbps
Protect		<ul style="list-style-type: none"> ● Peak overcurrent action value $8A \pm 10\%$ ● Overvoltage voltage action value 160VDC ● The threshold for over differential alarm can be set through a handheld intelligent regulator
External dimensions (mm)		111.5×75.5×34
weight		about300g
Send use ring Environment	Occasion	Try to avoid dust, oil mist, and corrosive gases as much as possible
	Operation temperature	0~70℃
	Storage temperature	-20℃~+80℃
	Humidity	40~90%RH
	Cooling Method	Natural cooling or forced cold air

5. Control signal wiring

5.1 Control signal single ended common anode wiring

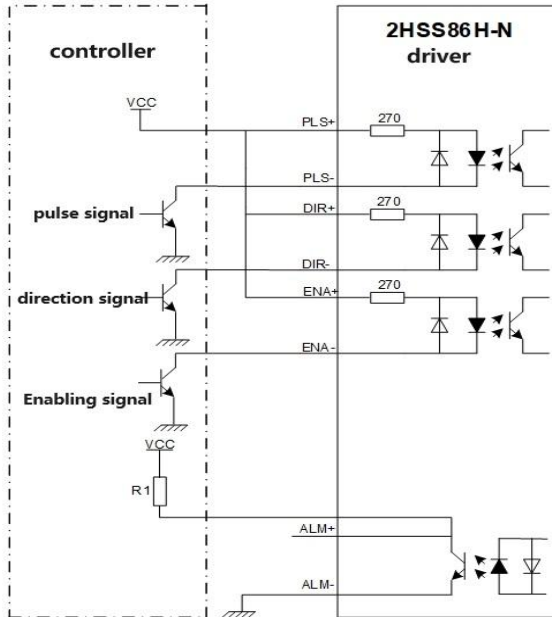

Attention: The control signal level can be compatible with 5V and 24V;

The resistor must be connected to the control signal terminal, R1=3~5K.

5.2 Control signal single ended common cathode wiring

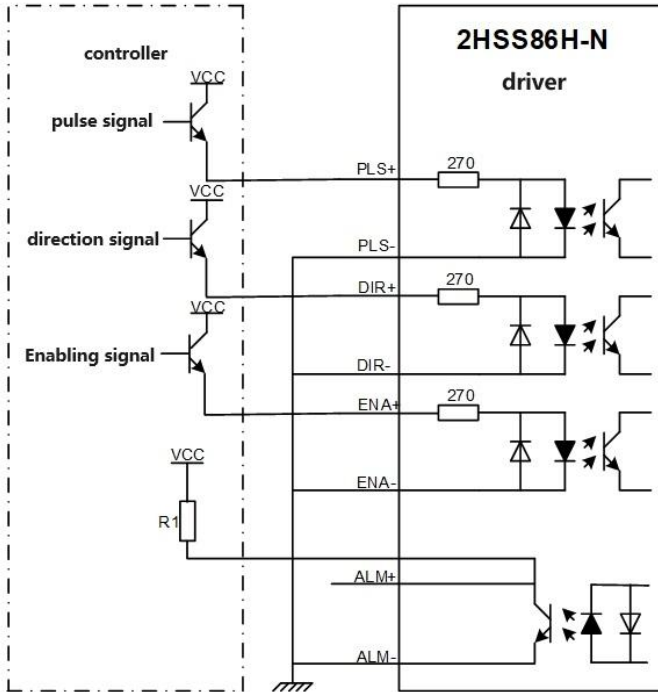

notice: The control signal level can be compatible with 5V and 24V;

The resistor must be connected to the control signal terminal,

R1=3~5K.

5.3 Differential wiring method for control signals

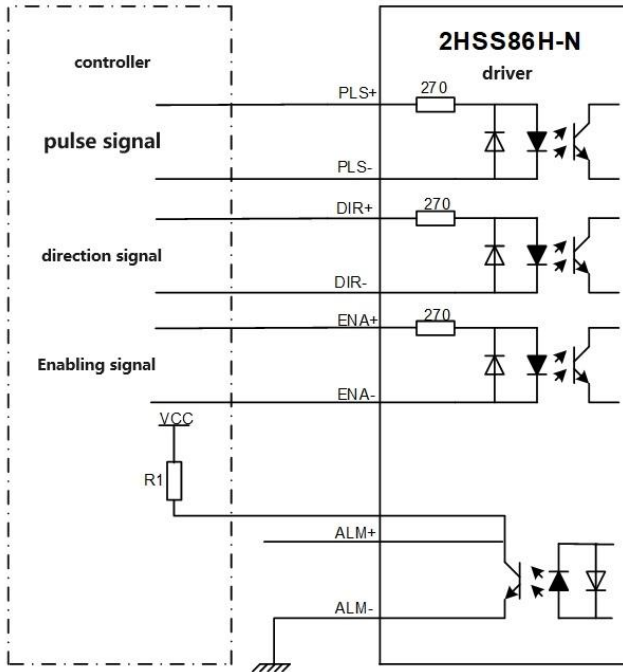

notice:The control signal level can be compatible with 5V and 24V;

The resistor must be connected to the control signal terminal, $R1=3\sim 5K$.

o

5.4 232 serial communication wiring diagram

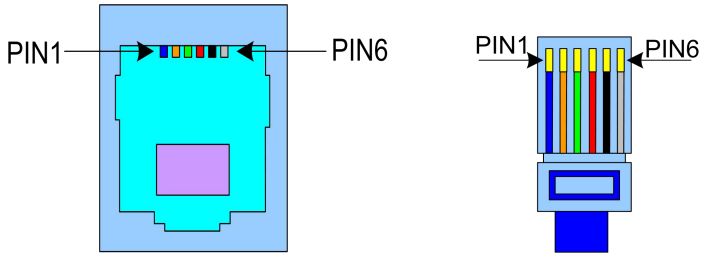

Crystal Head and Foot Position	define	illustrate
1	TXD	Sender
2	RXD	receiving terminal
4	+5V	For external HISU only
6	GND	Power supply ground

5.5 Control signal timing diagram

In order to avoid some misoperations and deviations, PLS, DIR, and ENA should meet certain requirements, as shown in Figure 3:

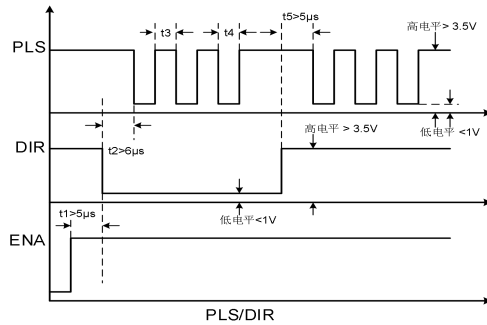

explanation:

(1) T1: ENA (enable signal) should have a minimum advance DIR of $5 \mu s$. Confirmed as high. In general, it is recommended to use ENA+and ENA - suspended.

(2) t2: At least advance PLS counting edge 6 for DIR μ Determine whether its state is high or low.

(3) T3: Pulse width not less than $2.5 \mu s$.

(4) T4: Low level width not less than $2.5 \mu s$.

6.Function dial and subdivision dial switch settings

6.1 SW1 single and double pulse selection

The SW1 dial switch selects single and double pulses, where off represents single pulse control (pulse+direction) and on represents double pulse control (pulse+pulse).

6.2 SW2 logic direction setting

When the SW2 toggle switch is turned off or on, the current direction of motor movement can be changed, with off=CCW and on=CW.

6.3 SW3-SW6 Subdivision Settings

The subdivision settings are shown in the table below. When SW3, SW4, SW5, and SW6 are all set to on, user-defined subdivision is effective. This value can be set through the parameter P20 of HISU.

Swift on Subdivision	SW3	SW4	SW5	SW6
Default	on	on	on	on
800	off	on	on	on
1600	on	off	on	on
3200	off	off	on	on

6400	on	on	off	on
12800	off	on	off	on
25600	on	off	off	on
51200	off	off	off	on
1000	on	on	on	off
2000	off	on	on	off
4000	on	off	on	off
5000	off	off	on	off
8000	on	on	off	off
10000	off	on	off	off
20000	on	off	off	off
40000	off	off	off	off

6.4 SW7 instruction smoothing setting

SW7 sets the command smoothing function. The off state does not enable the command smoothing function, while the on state enables the command smoothing function. The smoothness level can be set through parameter P19 of HISU. Please refer to the parameter list for specific parameter settings.

6.5 SW8 open/closed loop mode selection

SW8 sets the open loop/closed-loop operation mode, with the off state being the closed-loop operation mode and the on

state being the open loop operation mode. If the customer chooses open-loop operation mode, the driver is a regular digital driver that can operate without the need for an encoder.

7. Error alarm and LED flashing frequency

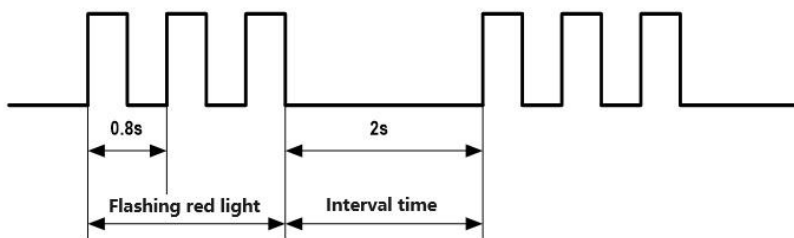

Number of red light flashes	Alarm Description
1	Drive overcurrent
2	Internal voltage reference error in the driver
3	Driver parameter upload error
4	The power supply voltage of the driver exceeds the maximum value
5	Driver position deviation exceeds the set value

6

Motor phase loss alarm

8. Installation dimensions

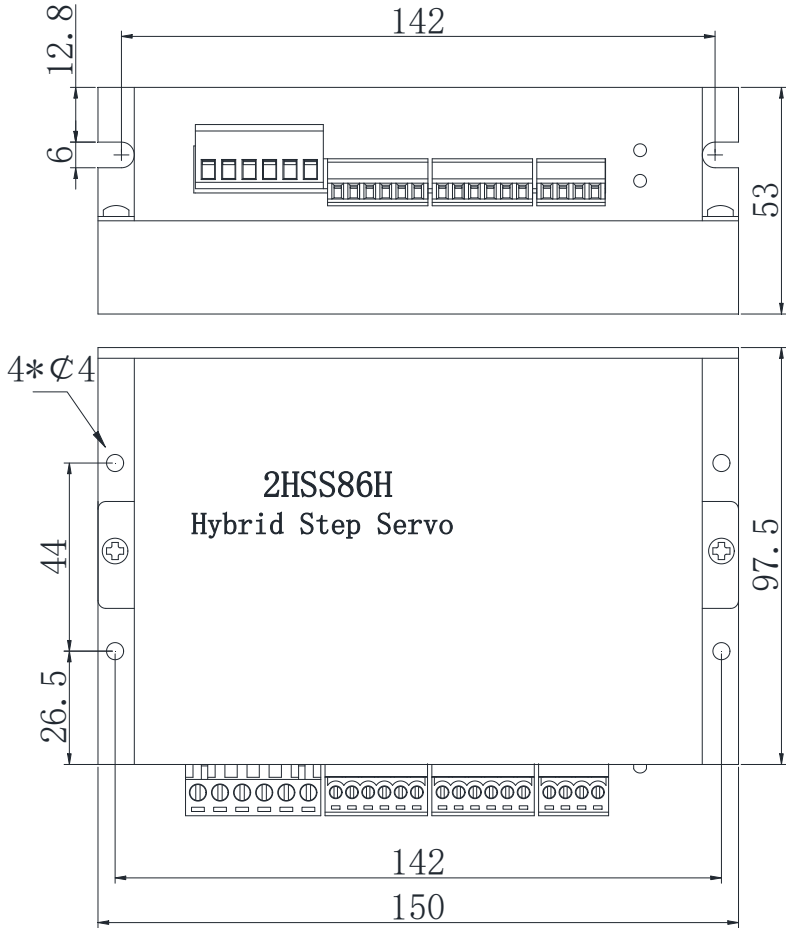

9.Wiring diagram

This driver can provide a +5V, maximum 80mA power supply to the encoder. Using a quadruple frequency counting method, the encoder resolution multiplied by four is the number of pulses per revolution of the stepper motor. The reference for 2HSS86H-N-XX is shown in the figure:

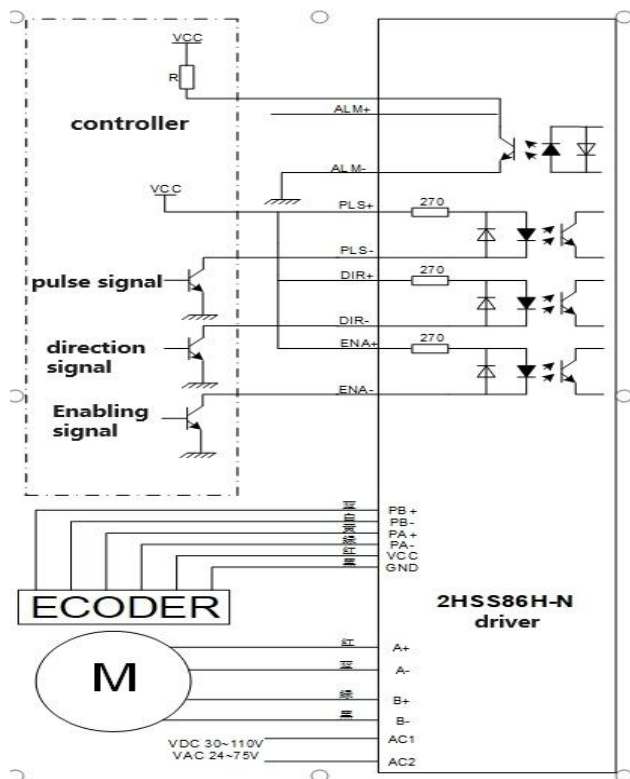

10.Parameter settings

The parameter setting method for the 2HSS86H-N. Driver is achieved through the RS232 serial communication port of the HISU debugger, using a dedicated debugging board to complete the parameter setting. The driver has a set of default factory configuration parameters corresponding to the best motor, and users only need to adjust the internal parameters of the driver according to specific usage situations. The specific parameters and functions are shown in the table below:

The actual value of the parameter=set value x corresponding dimension

Serial Number	name	range	dimensi on	restart drive	default parameter
P1	Current loop proportional gain	0—9000	0.0001	Yes	1000
P2	Current loop integral gain	0—2000	0.0001	No	100
P3	Driver damping coefficient	0—1000	0.0001	No	30
P4	Position loop proportional	0—3000	0.002	No	2000

	gain				
P5	Position loop integral gain	0—1000	0.01	No	200
P6	Speed loop proportional gain	0—3000	0.00001	No	300
P7	Speed loop integral gain	0—1000	0.00001	No	1000
P8	Driver open-loop current	0—60	0.1	No	40
P9	Driver closed-loop current	0—40	0.1	No	20
P10	Driver alarm level	0—1	1	No	1
P11	reserve	reserve	reserve	reserve	reserve
P12	reserve	reserve	reserve	reserve	reserve
P13	Driver Enable Level	0—1	1	No	0
P14	Driver in place level	0—1	1	No	1
P15	Encoder line selection	0—1	1	Yes	0
P16	Driver position out	0—3000	10	No	400

	of tolerance				
P17	reserve	reserve	reserve	reserve	reserve
P18	reserve	reserve	reserve	reserve	reserve
P19	Driver instruction smoothing	0—10	0	No	2
P20	User defined segmentation	4—1000	50	Yes	8
P21	reserve	reserve	reserve	reserve	reserve
P22	Pulse filtering	0-1000	4	Yes	3
P23	Drive Enable Lock	0—1	1	No	0
P24	reserve	reserve	reserve	reserve	reserve
P25	Open loop stacking ratio	0—40	1	No	20
P26	In place output threshold	0—1000	1	No	10
P27	reserve	reserve	reserve	reserve	reserve
P28	Manufacturer parameters	reserve	reserve	reserve	reserve
P29	Manufacturer	reserve	reserve	reserve	reserve

	parameters			e	
P30	Driver phase loss detection	0—1	1	Yes	1
P31	reserve	reserve	reserve	reserve	reserve
P32	reserve	reserve	reserve	reserve	reserve
P33	reserve	reserve	reserve	reserve	reserve
P34	reserve	reserve	reserve	reserve	reserve
P35	reserve	reserve	reserve	reserve	reserve
P36	Pulse set value (Read Only)	Read only parameters			
P37	Encoder feedback value (read-only)	Read only parameters			
P38	Position deviation value (Read Only)	Read only parameters			
P39	Program Erase	0-4000	1	Yes	0

This driver has a total of 39 parameters that can be adjusted:

The parameters P1, P2, P3, P4, P5, P6, and P7 are used to set the current loop, system damping coefficient, speed loop, and position loop, respectively.

Parameters P8 and P9 are used to set the open-loop control current and closed-loop control current, respectively. (Actual current=open-loop current+closed-loop current)

Parameter P10, used for alarm output level selection, set to 1 to indicate that the coupling output transistor is cut off during normal operation; When the driver alarms, the coupling output transistor conducts. The opposite is also true.

Parameter P11, reserve

Parameter P12, reserve

Parameter P13 is used to enable the level selection of the signal. Generally, 0 is selected for low-level enable, which means no external enable input signal is required. The opposite is also true.

Parameter P14, select the position output level, set to 1 to indicate that the driver meets the position condition and the coupling output transistor is cut off; The optocoupler output transistor is conducting when the in place condition is not met. The opposite is also true.

Parameter P15, encoder line selection, where 0 represents 1000 lines and 1 represents 2500 lines.

Parameter P16, set the threshold for position deviation.
(Actual value=set value * 10)

Parameter P17, reserve。

Parameter P18, reserve。

Parameter P19, command smoothing coefficient, with a total of 10 levels. The larger the value, the greater the smoothness of the command.

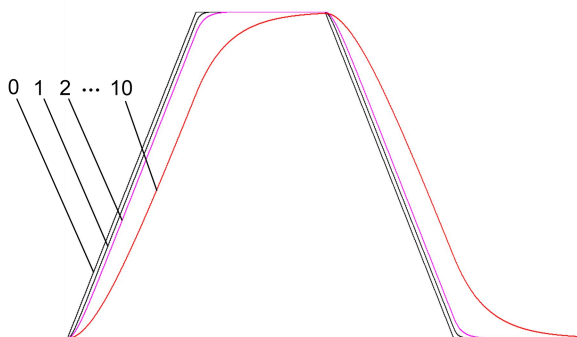

Parameter P20, subdivide the dialing to all on positions, enable user defined subdivision function, custom subdivision value= $P20 * 50$. For example, if the customer requests the use of 6000 subdivision, the first step is to set P20 to 120, and at the same time, set the subdivision dial to the full on gear. After re powering on, the drive dial is set to 6000 subdivision; if the subdivision code is Yes for screen printing other gears, the

corresponding subdivision value is the value corresponding to the subdivision table.

Parameter P21, reserve。

Parameter P22, pulse filtering settings. When the parameter is 0 (default parameter is 0), the filtering degree can be directly selected using the function dial code; When the parameters are set to other values, use the set parameters to set the filtering degree.

Parameter P23, Driver Enable Lock. When this parameter is 0, given the enable signal, the motor does not lock the shaft and the driver does not count external pulses. When this parameter is 1, given an enable signal, the motor locks the shaft and the driver does not count external pulses.

Parameter P24, reserve。

Parameter P25, open loop switching count.

Parameter P26, set the output threshold in place. Used to set the threshold for determining position deviation when outputting in place.

Parameter P27-29, reserve。

Parameter P30, enable phase loss function. When the parameter is 0 (default parameter is 0), the phase loss alarm

function is turned off, and when the parameter is 1, the phase loss alarm is turned on.

Parameters P31-35, reserve。

Parameter P36, used to monitor the position value given by the pulse.

Parameter P37, used to monitor the position value feedback from the encoder.

Parameter P38, used to monitor the deviation values given and feedback.

Parameter P39, program for erasing the drive. When this parameter is written to 2929, the program of the drive is automatically erased. Warning: This parameter is only for manufacturer use.

11.Common problems and troubleshooting

11.1 The power light is not on

Input power failure, please check the power circuit. Is the voltage too low

11.2 Power on with red light warning

- Check if the motor feedback signal line and motor power phase line are connected
- Is the input power voltage of the stepper servo driver too high or too low

11.3 After running and rotating for a small angle, the red light will light up and give an alarm

- Is the phase sequence of the motor connected correctly.
If it is not correct, please refer to the motor identification and the corresponding phase sequence connection of the driver.

Is the number of lines for the motor encoder consistent with the actual parameters of the connected motor in the driver configuration parameters. If different, reset

Does the pulse input speed exceed the rated speed of the motor, resulting in positional deviation.

11.4 Does not rotate after pulse input

- Is the wiring of the pulse input terminal of the stepper servo driver reliable.
- Is the input method in the configuration of the stepper servo drive system a pulse input related input method.
- Is the motor able to be released.