



杰美康机电  
JUST MOTION CONTROL

# 2HSS86H-A

## Hybrid Stepper Servo Drive

---

# Manual



Shenzhen **Just Motion Control** Electro-mechanics Co., Ltd

TEL:+86-0755-26509689

FAX:+86-0755-26509289

[www.jmc-motion.com](http://www.jmc-motion.com)

Email:[info@jmc-motion.com](mailto:info@jmc-motion.com)

Address: Floor2, Building A, Hongwei Industrial Zone No.6,

Liuxian 3rd Road, Shenzhen. China

Thanks for selecting JMC stepper motor driver. We hope that the superior performance, outstanding quality, excellent cost performance of our product can help you accomplish your motion control project.

The content in this manual has been carefully prepared and is believed to be accurate, but no responsibility is assumed for inaccuracies.

All the contents of this manual, copyright is owned by the Shenzhen JUST MOTION CONTROL electromechanical Co., Ltd. Without JMC permission, no unit or individual is allowed to copy.

Shenzhen Just Motion Control  
Electro-mechanics Co., Ltd

Version	Editor	Verifier
V1.1	R&D	R&D

## Contents

<b>1. Overview</b> .....	- 4 -
<b>2. Features</b> .....	- 4 -
<b>3. Ports Introduction</b> .....	- 5 -
3.1 ALM and PEND signal output ports.....	- 5 -
3.2 Control Signal Input Ports.....	- 5 -
3.3 Encoder Feedback Signal Input Ports.....	- 6 -
3.4 Power Interface Ports.....	- 7 -
<b>4. Technological Index</b> .....	- 8 -
<b>5. Connections to Control Signal</b> .....	- 9 -
5.1 Connections to Common Anode.....	- 9 -
5.2 Connections to Common Cathode.....	- 10 -
5.3 Connections to Differential Signal.....	- 11 -
5.4 Connections to 232 Serial Communication Interface.....	- 12 -
5.5 Sequence Chart of Control Signals.....	- 12 -
<b>6. DIP Switch Setting</b> .....	- 13 -
6.1 Activate Edge Setting.....	- 13 -
6.2 Running Direction Setting.....	- 14 -
6.3 Micro steps Setting.....	- 14 -
<b>7. Faults alarm and LED flicker frequency</b> .....	- 15 -
<b>8. Appearance and Installation Dimensions</b> .....	- 16 -
<b>9. Typical Connection</b> .....	- 16 -
<b>10. Parameter Setting</b> .....	- 17 -
<b>11. Processing Methods to Common Problems and Faults</b> .....	- 22 -
11.1 Power on power light off.....	- 22 -
11.2 Power on red alarm light on.....	- 22 -
11.3 Red alarm light on after the motor running a small angle..	- 22 -
11.4 After input pulse signal but the motor not running.....	- 23 -

## 1. Overview

The HSS86H-A hybrid stepper servo drive system integrates the servo control technology into the digital stepper drive perfectly. And this product adopts an optical encoder with high speed position sampling feedback of 50  $\mu$  s, once the position deviation appears, it will be fixed immediately. This product is compatible the advantages of the stepper drive and the servo drive, such as lower heat, less vibration, fast acceleration, and so on. This kind of servo drive also has an excellent cost performance.

## 2. Features

- ◆ Without losing step, High accuracy in positioning
- ◆ 100% rated output torque
- ◆ Variable current control technology, High current efficiency
- ◆ Small vibration, Smooth and reliable moving at low speed
- ◆ Accelerate and decelerate control inside, Great improvement in smoothness of starting or stopping the motor
- ◆ User-defined micro steps
- ◆ Compatible with 1000 and 2500 lines encoder
- ◆ No adjustment in general applications
- ◆ Over current, over voltage and over position error protection
- ◆ Green light means running while red light means protection or off line

### 3. Ports Introduction

#### 3.1 ALM and PEND signal output ports

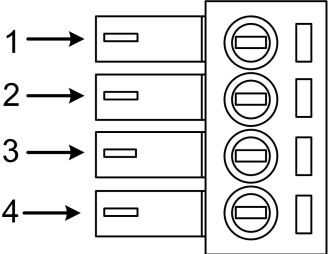

Port	Symbol	Name	Remark
1	PEND+	In position signal output +	
2	PEND-	In position signal output -	
3	ALM+	Alarm output +	
4	ALM-	Alarm output -	

#### 3.2 Control Signal Input Ports

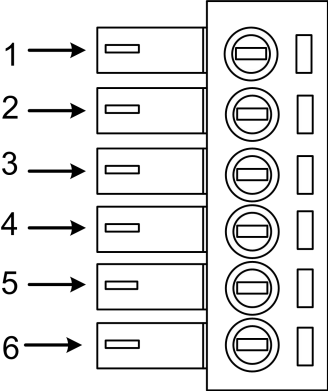

Port	Symbol	Name	Remark
1	PLS+	Pulse signal +	Compatible with 5V or 24V
2	PLS-	Pulse signal -	
3	DIR+	Direction signal+	Compatible with 5V or 24V
4	DIR-	Direction signal-	
5	ENA+	Enable signal +	Compatible with 5V or 24V
6	ENA-	Enable signal -	

### 3.3 Encoder Feedback Signal Input Ports

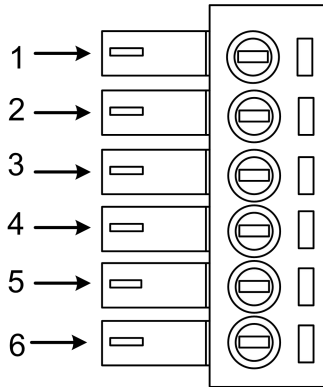

Port	Symbol	Name	Wiring color
1	PB+	Encoder phase B +	Blue
2	PB-	Encoder phase B -	White
3	PA+	Encoder phase A +	Yellow
4	PA-	Encoder phase A -	Green
5	VCC	Input power	Red
6	GND	Input power ground	Black

### 3.4 Power Interface Ports

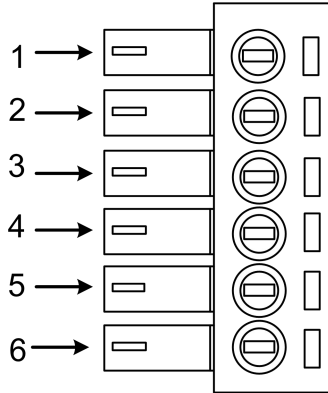

Port	Identification	Symbol	Name	Remark
1	Motor Phase	A+	Phase A+ (Red)	Motor Phase A
2		A-	Phase A- (Blue)	
3	Wire Input Ports	B+	Phase B+ (Green)	Motor Phase B
4		B-	Phase B- (Black)	
5	Power Input Ports	VCC	Input Power +	AC24V-70V
6		GND	Input Power-	DC30V-100V

## 4. Technological Index

Input Voltage	24~70VAC or 30~100VDC	
Output Current	6A 20KHz PWM	
Pulse Frequency max	200K	
Communication rate	57.6Kbps	
Protection	<ul style="list-style-type: none"> <li>● Over current peak value 12A±10%</li> <li>● Over voltage value 130V</li> <li>● The over position error range can be set through the HISU</li> </ul>	
Overall Dimensions (mm)	150×97.5×53	
Weight	Approximate 580g	
Environment Specifications	Environment	Avoid dust, oil fog and corrosive gases
	Operating Temperature	70°C Max
	Storage Temperature	-20°C~+65°C
	Humidity	40~90%RH
	Cooling method	Natural cooling or forced air cooling



## 5. Connections to Control Signal

### 5.1 Connections to Common Anode

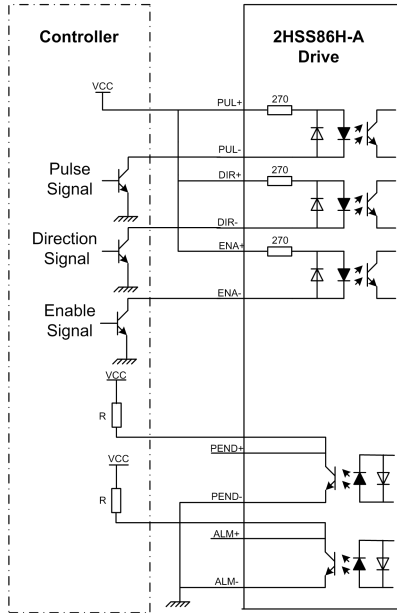

#### Remark:

VCC is compatible with 5V or 24V;

R(3~5K) must be connected to control signal terminal.

## 5.2 Connections to Common Cathode

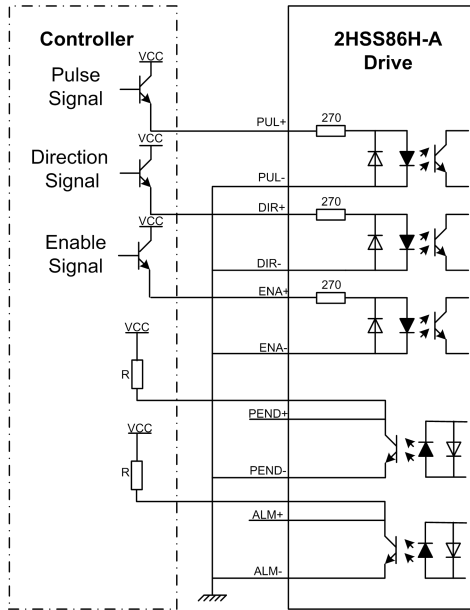

**Remark:**

VCC is compatible with 5V or 24V;

R(3~5K) must be connected to control signal terminal.

### 5.3 Connections to Differential Signal

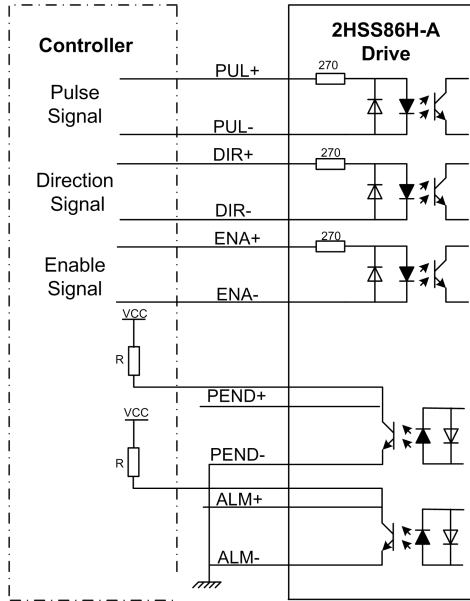

**Remark:**

VCC is compatible with 5V or 24V;

R(3~5K) must be connected to control signal terminal.

## 5.4 Connections to 232 Serial Communication Interface

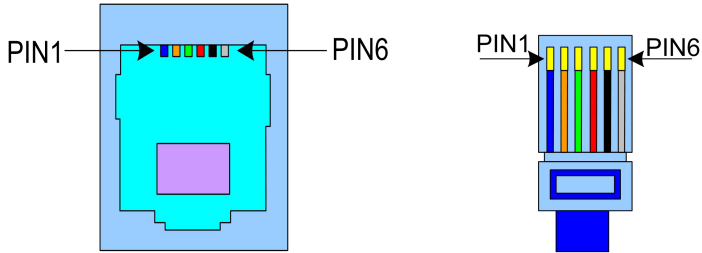

Crystal Head foot	Definition	Remark
1	TXD	Transmit Data
2	RXD	Receive Data
4	+5V	Power Supply to HISU
6	GND	Power Ground

## 5.5 Sequence Chart of Control Signals

In order to avoid some fault operations and deviations, PUL, DIR and ENA should abide by some rules, shown as following diagram:

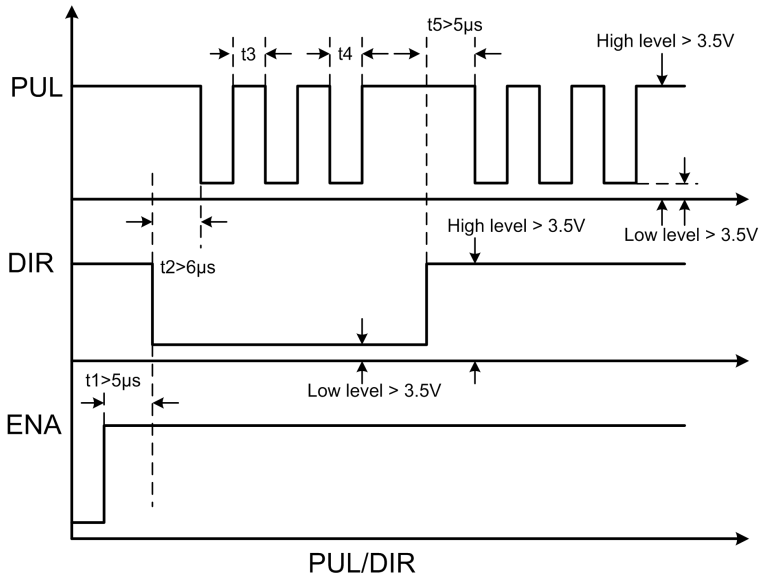

### Remark:

- $t_1$ : ENA must be ahead of DIR by at least  $5\mu\text{s}$ . Usually, ENA+ and ENA- are NC (not connected).
- $t_2$ : DIR must be ahead of PUL active edge by  $6\mu\text{s}$  to ensure correct direction;
- $t_3$ : Pulse width not less than  $2.5\mu\text{s}$ ;
- $t_4$ : Low level width not less than  $2.5\mu\text{s}$ .

## 6. DIP Switch Setting

### 6.1 Activate Edge Setting

SW1 is used for setting the activate edge of the input signal, “off” means the activate edge is the rising edge, while “on” is the falling edge.

## 6.2 Running Direction Setting

SW2 is used for setting the running direction, “off” means CCW, while “on” means CW.

## 6.3 Micro steps Setting

The micro steps setting is in the following table, while SW3、SW4、SW5、SW6 are all on, the internal default micro steps inside is activate, this ratio can be setting through the HISU.

Dial switch Micro steps	SW3	SW4	SW5	SW6
Default	on	on	on	on
800	off	on	on	on
1600	on	off	on	on
3200	off	off	on	on
6400	on	on	off	on
12800	off	on	off	on
25600	on	off	off	on
51200	off	off	off	on
1000	on	on	on	off
2000	off	on	on	off
4000	on	off	on	off
5000	off	off	on	off

8000	on	on	off	off
10000	off	on	off	off
20000	on	off	off	off
40000	off	off	off	off

## 7. Faults alarm and LED flicker frequency

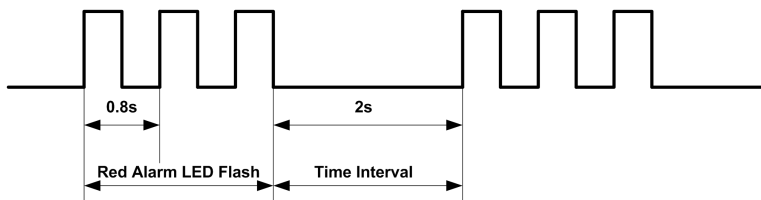

Flicker Frequency	Description to the Faults
1	Error occurs when the motor coil current exceeds the drive's current limit.
2	Voltage reference error in the drive
3	Parameters upload error in the drive
4	Error occurs when the input voltage exceeds the drive's voltage limit.
5	Error occurs when the actual position following error exceeds the limit which is set by <b>the position error limit</b> .

## 8. Appearance and Installation Dimensions

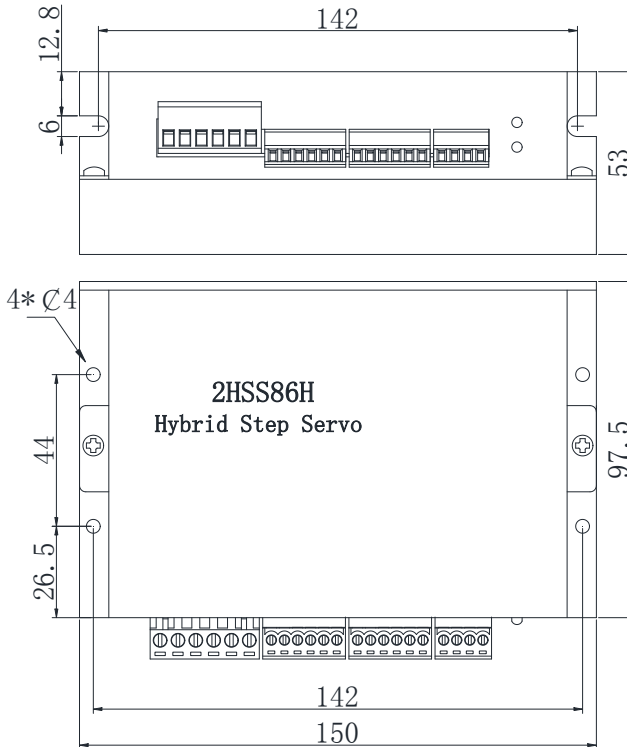

## 9. Typical Connection

This drive can provide the encoder with a power supply of +5v, maximum current 80mA. It adopts a quadruplicated-frequency counting method, and the resolution ratio of the encoder multiply 4 are the pulses per rotate of the servo motor. Here is the typical connection of



2HSS86H-A.

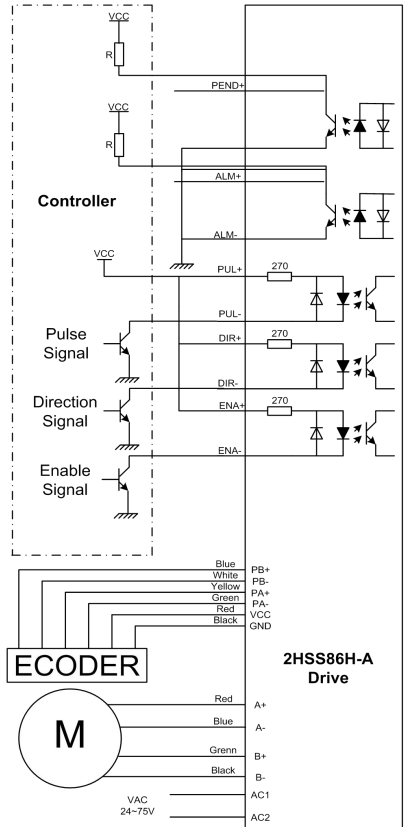

### 10. Parameter Setting

The parameter setting method of 2HSS86H-A drive is to use a HISU adjuster through the 232 serial communication ports, only in this way can we setting the parameters we want. There are a set of best default parameters to the corresponding motor which are carefully adjusted by

our engineers, users only need refer to the following table, specific condition and set the correct parameters.

**Actual value = Set value × the corresponding dimension**

Mode	Definition	Range	Dimension	Drive Restart	Default Value
P1	Current loop Kp	0—4000	1	N	1000
P2	Current loop Ki	0—1000	1	N	100
P3	Damping coefficient	0—1000	1	N	100
P4	Position loop Kp	0—4000	1	N	2000
P5	Position loop Ki	0—1000	1	N	150
P6	Speed loop Kp	0—3000	1	N	350
P7	Position loop Ki	0—1000	1	N	100
P8	Open loop current	0—60	0.1	N	45
P9	Close loop current	0—40	0.1	N	20
P10	Alarm level	0—1	1	N	0
P11	Reserved				
P12	Stop lock enable	0—1	1	N	0
P13	Enable signal level	0—1	1	N	0
P14	Arrival level	0—1	1	N	1
P15	Encoder line number	0—1	1	Y	0
P16	Position error limit	0—3000	10	N	1000
P17	Reserved				
P18	Reserved				
P19	Speed smoothness	0—10	1	N	0
P20	User-defined p/r	4-1000	50	Y	8

There are total 20 parameter configurations, use the HISU to download the configured parameters to the drive, the detail descriptions to every parameter configuration are as follows:

Item	Description
<b>Current loop Kp</b>	Increase Kp to make current rise fast. Proportional Gain determines the response of the drive to setting command. Low Proportional Gain provides a stable system (doesn't oscillate), has low stiffness, and the current error, causing poor performances in tracking current setting command in each step. Too large proportional gain values will cause oscillations and unstable system.
<b>Current loop Ki</b>	Adjust Ki to reduce the steady error. Integral Gain helps the drive to overcome static current errors. A low or zero value for Integral Gain may have current errors at rest. Increasing the integral gain can reduce the error. If the Integral Gain is too large, the system may "hunt" (oscillate) around the desired position.
<b>Damping coefficient</b>	This parameter is used to change the damping coefficient in case of the desired operating state is under resonance frequency.
<b>Position loop Kp</b> <b>Position loop Ki</b>	The PI parameters of the position loop. The default values are suitable for most of the application, you don't need to change them. Contact us if you have any question.

<b>Speed loop Kp</b>	The PI parameters of the speed loop. The default values are suitable for most of the application, you don't need to change them. Contact us if you have any question.
<b>Speed loop Ki</b>	
<b>Open loop current</b>	This parameter affects the static torque of the motor.
<b>Close loop current</b>	This parameter affects the dynamic torque of the motor. (The actual current = open loop current + close loop current)
<b>Alarm Control</b>	This parameter is set to control the Alarm optocoupler output transistor. 0 means the transistor is cut off when the system is in normal working, but when it comes to fault of the drive, the transistor becomes conductive. 1 means opposite to 0.
<b>Stop lock enable</b>	This parameter is set to enable the stop clock of the drive. 1 means enable this function while 0 means disable it.
<b>Enable Control</b>	This parameter is set to control the Enable input signal level, 0 means low, while 1 means high.
<b>Arrival Control</b>	This parameter is set to control the Arrival optocoupler output transistor. 0 means the transistor is cut off when the drive satisfies the arrival

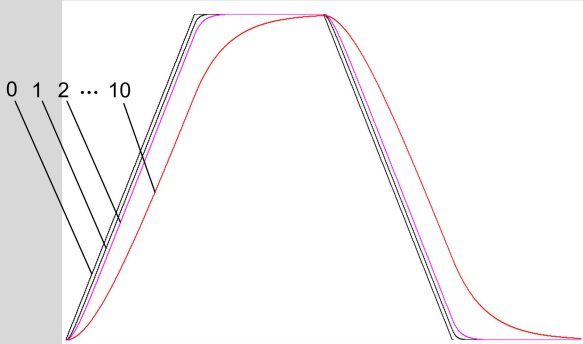
	command, but when it comes to not, the transistor becomes conductive. 1 means opposite to 0.
<b>Encoder resolution</b>	This drive provides two choices of the number of lines of the encoder. 0 means 1000 lines, while 1 means 2500 lines.
<b>Position error limit</b>	The limit of the position following error. When the actual position error exceeds this value, the drive will go into error mode and the fault output will be activated. (The actual value = the set value $\times$ 10)
<b>Speed smoothness</b>	<p>This parameter is set to control the smoothness of the speed of the motor while acceleration or deceleration, the larger the value, the smoother the speed in acceleration or deceleration.</p> 
<b>User-defined p/r</b>	This parameter is set of user-defined pulse per revolution, the internal default micro steps inside is activate while SW3、SW4、SW5、SW6 are all on,

users can also set the micro steps by the outer DIP switches. (The actual micro steps = the set value  $\times$  50)

## **11. Processing Methods to Common Problems and Faults**

### **11.1 Power on power light off**

- No power input, please check the power supply circuit. The voltage is too low.

### **11.2 Power on red alarm light on**

- Please check the motor feedback signal and if the motor is connected with the drive.
- The stepper servo drive is over voltage or under voltage. Please lower or increase the input voltage.

### **11.3 Red alarm light on after the motor running a small angle**

- Please check the motor phase wires if they are connected correctly, if not, please refer to the 3.4 Power Ports.
- Please check the parameter in the drive if the poles of the motor and the encoder lines are corresponding with the real parameters, if not, set them correctly.

- Please check if the frequency of the pulse signal is too fast, thus the motor may be out of its rated speed, and lead to position error.

#### **11.4 After input pulse signal but the motor not running**

- Please check the input pulse signal wires are connected in reliable way.
- Please make sure the input pulse mode is corresponding with the real input mode.