



杰美康机电
JUST MOTION CONTROL

3HSS2208H-86

High Voltage Digital Stepper Servo Drive Manual



Email: info@jmc-motion.com

Address: Floor2, Building A, Hongwei Industrial Zone No.6,
Liuxian 3rd Road, Shenzhen. China

Shenzhen Just Motion Control Electro-mechanics Co., Ltd

TEL:+86-0755-26509689 26502268

FAX:+86-0755-26509289

Http://www.jmc-motion.com

Thanks for selecting JMC stepper motor driver. We hope that the superior performance, outstanding quality, excellent cost performance of our product can help you accomplish your motion control project.

The content in this manual has been carefully prepared and is believed to be accurate, but no responsibility is assumed for inaccuracies.

All the contents of this manual, copyright is owned by the Shenzhen JUST MOTION CONTROL electromechanical Co., Ltd. Without JMC permission, no unit or individual is allowed to copy.

Shenzhen Just Motion Control

Electro-mechanics Co., Ltd

Version	Editor	Verifier

Contents

1. Brief Introduction	4
1.1 Overview	4
1.2 Features	4
1.3 Applications.....	5
2. Technical Index	5
2.1 Electrical and Environment Specifications	5
2.2 Mechanical Specifications	6
2.3 Elimination of Heat.....	7
3. Fault Data Display	7
4. Ports and Connections Introduction	8
4.1 Ports Definition	8
4.1.1 Power Interface Ports1	8
4.1.2 Power Interface Ports2	8
4.1.3 Control Signal Interface Ports (44 Pins DB)	9
4.1.4 RS232 Communication Interface Ports.....	9
4.1.5 Status Indicator	10
5. Connections to Control Signal	11
6. Sequence Chart of Control Signal	13
7. Connections to Encoder	14
8. Connections to Serial Interface	14
9. Drive' Parameters Configure	14
10. Parameter adjustment method	20
10.1 Button Panel Operation	20
10.2 Mode Configure Operation Example	20
10.3 Parameter Configure Operation Example	21
11. Typical Connections to 3HSS2208H-86	22
12. Processing Methods to Common Problems and Faults	23
12.1 Power on but no digital tube display	23
12.2 Power on or after the motor running a small angle and fault data display ..	23
12.3 After input pulse signal but the motor not running.....	24

1. Brief Introduction

1.1 Overview

The 3HSS2208H-86 stepper servo drive system integrates the servo control technology into the digital stepper drive perfectly, and fit the company 86 three-phase stepper motor. This stepper servo driver uses the latest 32-bit DSP and combines the advanced servo algorithm to control. Compared to the traditional step drive, this step servo driver can completely avoid the stepper motor lost step problem, and effectively restrain the temperature rise of the motor, reduce the motor vibration, greatly enhance the performance of high-speed motor. The driver is half price of the AC servo system. At the same time, the size of the adapter is compatible with the traditional step motor, which is convenient for customers to upgrade and replace. In short, the stepper servo driver set the advantages of no lost step, low temperature rise, high speed, high torque, low cost and so on in one, is a cost-effective high motion control products.

1.2 Features

- Without losing step, High accuracy in position
- 100% rated output torque
- Variable current control technology, High current efficiency
- Little vibration, Smooth and reliable moving at low speed
- Accelerate and decelerate control inside, Great improvement in

smoothness of starting or stopping the motor

- User-defined micro steps
- Compatible with 1000 and 2500 lines encoder
- No adjustment in general application
- Lack of phase, over current, over voltage and over position protection
- Six digital tube display, easy to set parameters and monitor the motor running state

1.3 Applications

It is suitable for the automation equipment and instrumentation which require large torque, such as: engraving machine, wire-stripping machine, marking machine, cutting machine, laser photocomposing machine, plotting instrument, numerical control machine tool, automatic assembly equipment and so on. The application results are especially good in the devices with little noise and high speed.

2. Technical Index

2.1 Electrical and Environment Specifications

Input Voltage	180~250VAC
Continuous Current Output	4.0A
Maximum Input Frequency	200K
Signal Input Current	7~20mA (10mA Typical)
Default Communication Rate	57.6Kbps
	● Over current peak value $12A \pm 10\%$

Protections		<ul style="list-style-type: none"> ● Over voltage value 400VDC ● The range of over position error can be set by the front panel or HISU
Overall Dimensions (mm)		140×70×56
Weight		Approximate 1500g
Environment specifications	Environment	Avoid dust, oil fog and corrosive gasses
	Operating Temperature	0~70°C
	Storage Temperature	-20°C ~+65°C
	Humidity	40~90%RH
	Cooling method	Natural cooling or forced air cooling

2.2 Mechanical Specifications

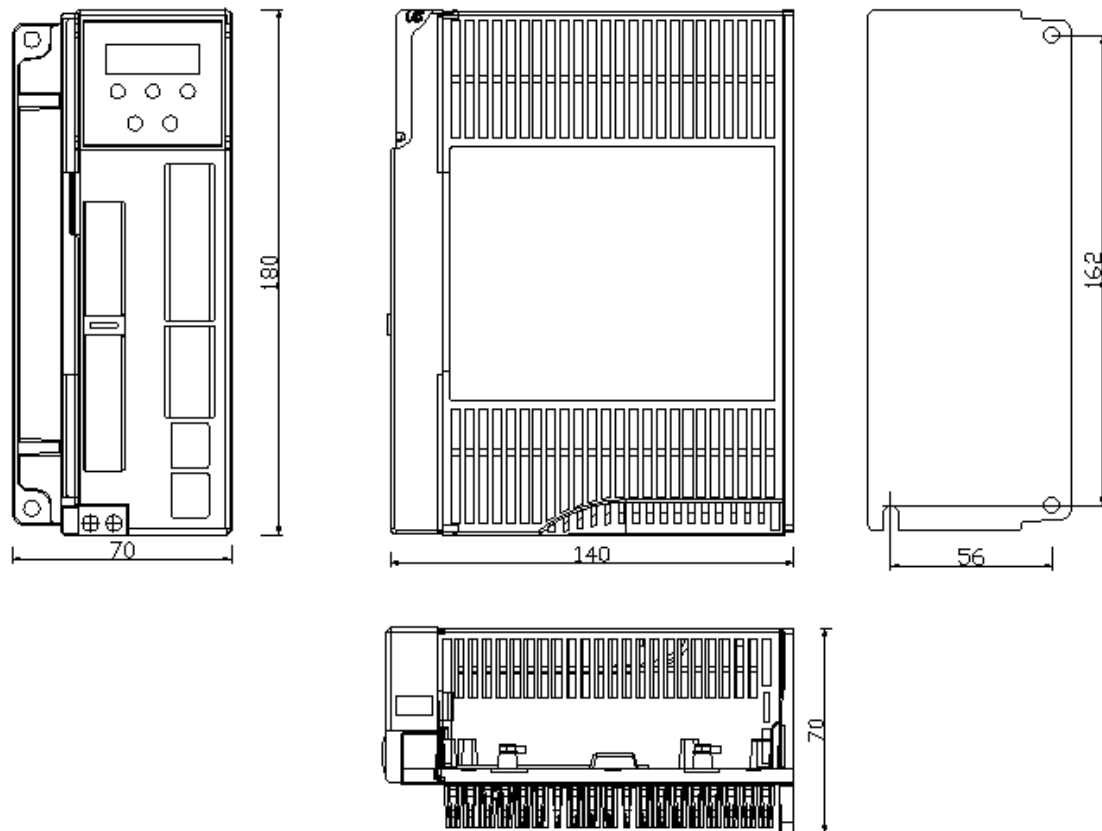

Fig. 1 Mechanical installation size (unit: mm)

Notice: Please take the terminal size and ventilation cooling while design the installation size.

2.3 Elimination of Heat

- ▶ Drive's reliable working temperature should be $<60^{\circ}\text{C}$, and motor working temperature should be $<90^{\circ}\text{C}$;
- ▶ It is recommended to mount the drive vertically to maximize heat sink area. Use forced cooling method to cool the system if necessary.

3. Fault Data Display

Data display	Fault cause
	Over current in the motor
	Current sensor alarm

22_Err	Parameters upload alarm
33_Err	Over voltage in power supply
44_Err	Over position error alarm
55_Err	Missing phase alarm
En_OFF	Drive off -line

4. Ports and Connections Introduction

4.1 Ports Definition

4.1.1 Power Interface Ports1

Port	Symbol	Definition	Remark
1	L	Power input port L	180~250VAC between L and N
2	N	Power input port N	
3	PE	Ground port	
4	NC	Not Connected	
5	NC	Not Connected	

4.1.2 Power Interface Ports2

Port	Symbol	Definition	Remark
1	U	Motor connection port U	
2	V	Motor connection port V	
3	W	Motor connection port W	
4	NC	Not connected	
5	PE	Ground port	
6	NC	Not connected	

4.1.3 Control Signal Interface Ports (44 Pins DB)

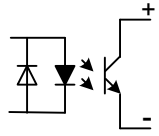
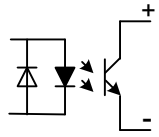
Port	Symbol	Definition	Remark
3	PUL+	Pulse signal input +	Compatible with 5V and 24V
4	PUL-	Pulse signal input -	
5	DIR+	Direction signal input +	Compatible with 5V and 24V
6	DIR-	Direction signal input -	
7	ALM+	Alarm signal output +	
8	ALM-	Alarm signal output -	
9	Pend+	Position signal output +	
10	Pend-	Position signal output -	
11	ENA+	Enable signal input +	Compatible with 5V and 24V
12	ENA-	Enable signal input -	

4.1.4 RS232 Communication Interface Ports

RS232 interface ports' arrangement and definition are as follows:

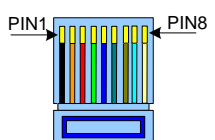
RS232	Connect to the PC or IHU adjuster with a special serial cable. Never disconnect or connect it while the power source is energized. It is suggested to use twisted-pair or shielded wire (less than 2m).		
Port	Symbol	Definition	Picture
1	GND	Power Ground	
2	TxD	RS232 Transmission Port	

3	5V	For external HISU	
4	RxD	RS232 Receiving Port	
5、6	NC	Not Connection	

Attention: In case of causing any damage, please confirm the connection



cables between 3HSS2208H-86 and HISU before using it.

4.1.5 Status Indicator

1. Control panel (including 5 buttons and 6 LED digital tube displays)

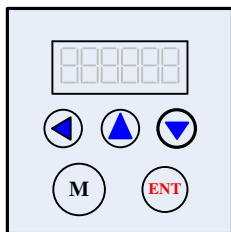

- ‘◀’ Button: Left shift Digits
- ‘▲’ Button: Decrease or Next
- ‘▼’ Button: Increase or Previous

Users can configure the drive via the on-board front panel. This panel includes six 7-segment digits and five keys for users operation as the picture show above.

Function Setting

- ‘ENT’ Button: Enter or Confirm
- ‘M’ Button: Exit or Mode switching

2. Functions are as follows:

Shift Setting:

LED Display	Definition	Remark
d00SPF	Reference Speed	
d01SPF	Speed Feedback	
d02PLE	Position Error	
d03PLR	Position Reference	

d04PLF	Position Feedback	
xx_Err	Drive Failure	
En_OFF	Drive offline	

Remark: Switch to Parameter display function via ‘M’; Check the parameter via ‘ENT’ (The power on display data is the final parameter you want to check), Switch functions via ‘▼’ or ‘▲’ (While ‘◀’ is valid); Exit or switch to the next function via ‘M’.

5. Connections to Control Signal

The connections to the input and output control signals are as follows:

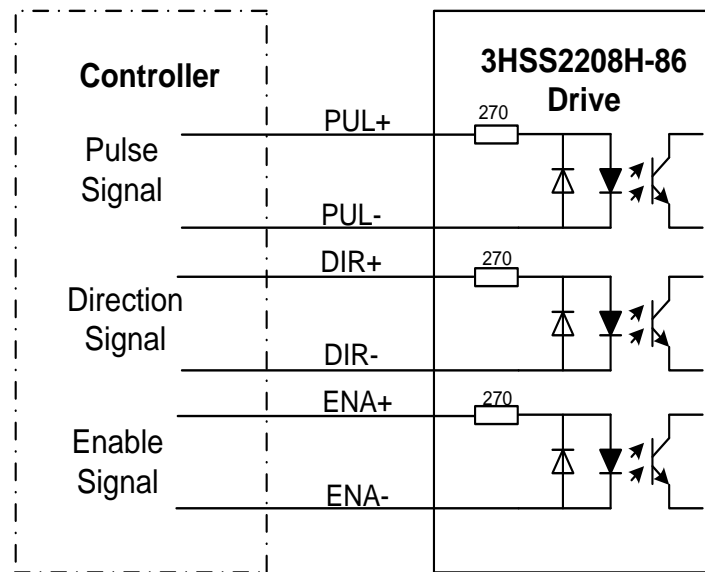

Fig. 2 Connections to differential signals

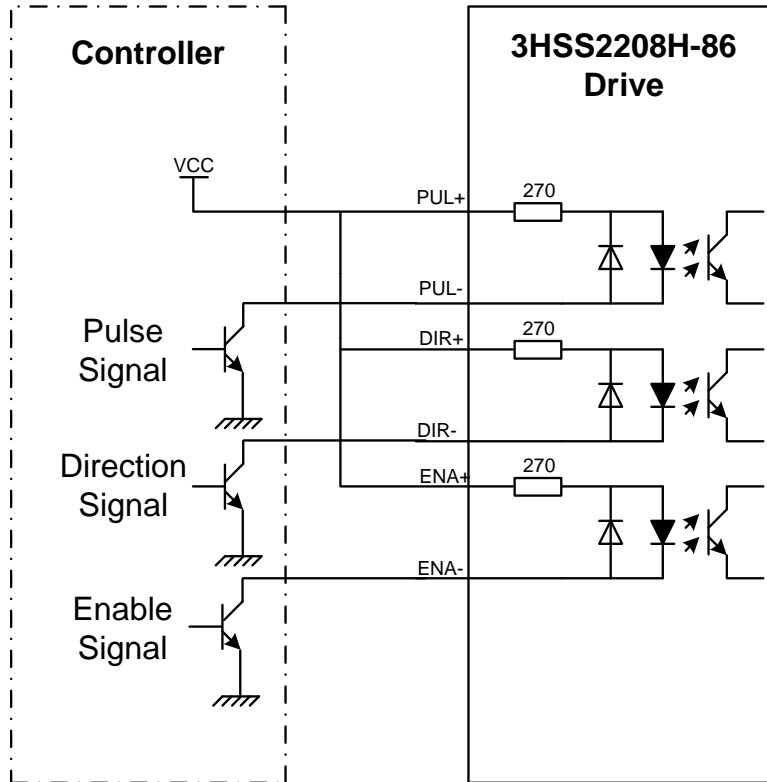

Fig. 3 Connections to common anode

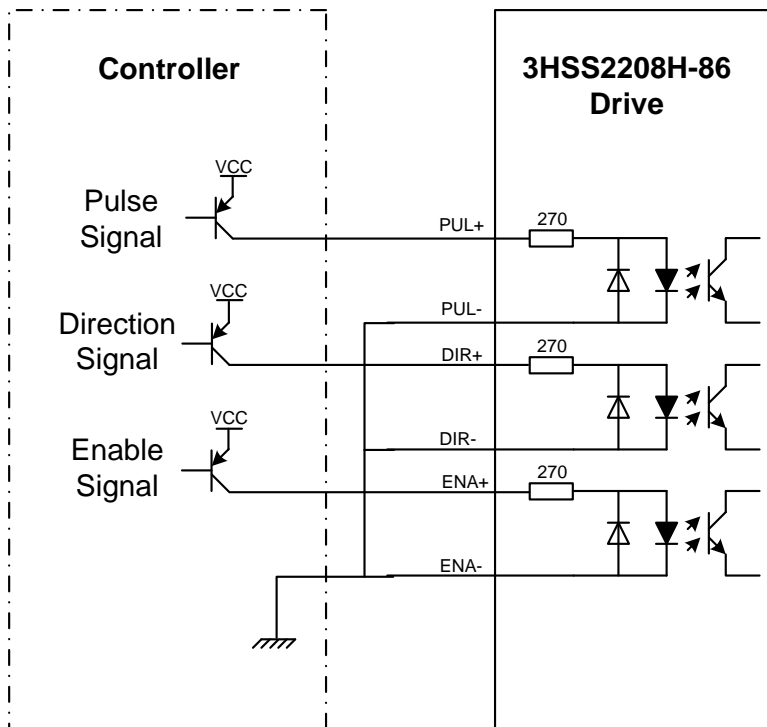

Fig. 4 Connections to common cathode



Attention: The control signal can be compatible with 5V and 24V.

6. Sequence Chart of Control Signal

In order to avoid some fault operations and deviations, PUL, DIR and ENA should abide by some rules, shown as following diagram:

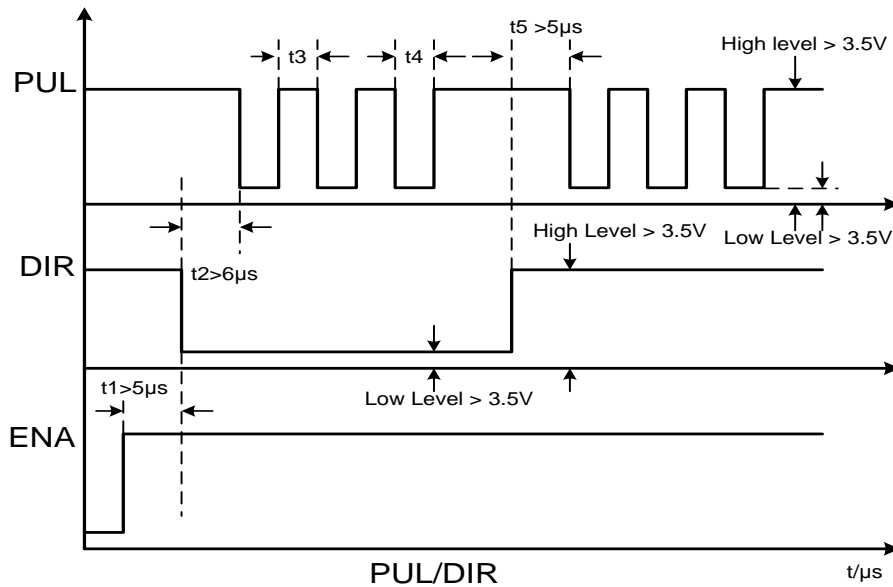

Fig. 5 Timing diagram of Control signal

Remark:

- (1) t_1 : ENA must be ahead of DIR by at least $6\mu\text{s}$. Usually, ENA+ and ENA- are NC (not connected). See “Connector P1 Configurations” for more information.
- (2) t_2 : DIR must be ahead of PUL active edge by at least $5\mu\text{s}$ to ensure correct direction;
- (3) t_3 : Pulse width not less than $2.5\mu\text{s}$;
- (4) t_4 : Low level width not less than $2.5\mu\text{s}$.

Control signal mode setting

The trigger pulse selection: drive through the front panel or HISU key board to set the pulse rising edge or falling edge triggered effectively.

7. Connections to Encoder

The connection wires of the encoder are designed with the extension wires of 15 pins and the motor encoder wires, and these special wires are provided by our company, users no need to connect them. The definitions of the 3HSS2208H-110 encoder interface ports are as follows:

DB Port	Signal	Description
1	EA+	Encoder Chanel A output +
2	EB+	Encoder Chanel B output +
3	GND	Encoder GND Input
11	EA-	Encoder Chanel A output -
12	EB-	Encoder Chanel B output -
13	VCC	Encoder Voltage Input +5V

8. Connections to Serial Interface

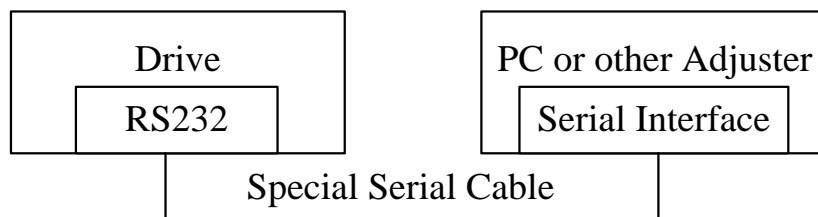

Fig. 6 Connections to serial interface

Attention:

In case of causing any damage, please confirm the connection cables between 3HSS2208H-86 and HISU before using it.

9. Drive' Parameters Configure

There two methods to configure parameters of 3HSS2208H-86, one

is set the parameters through the front panel, the other way is to connect it with the HISU. A set of the best default configure parameters has already set in the drive, user only need to configure the parameter Pulses/revolution, the detail functions are as follows:

Actual value = Set value × the corresponding dimension

Mo de	Definition	Range	Dime- nsion	Restart Drive	Default Value
P0	Reset	0—100	11	N	0
P1	Current loop Kp	0—4000	1	N	1000
P2	Current loop Ki	0—1000	1	N	100
P3	Damping coefficient	0—500	1	N	100
P4	Position loop Kp	0—3000	1	N	2000
P5	Position loop Ki	0—1000	1	N	150
P6	Speed loop Kp	0—3000	1	N	1250
P7	Speed loop Ki	0—1000	1	N	250
P8	Open-loop current	0—60	0.1	N	19
P9	Close-loop current	0—40	0.1	N	10
P10	Alarm level	0—1	1	N	0
P11	Direction level	0—1	1	Y	0
P12	Pulse edge	0—1	1	Y	0
P13	Enable level	0—1	1	N	0

P14	Arrival level	0—1	1	N	1
P15	Encoder line number	0—1	1	Y	0
P16	Position error limit	0—3000	10	N	1000
P17	Subdivision Selection	0—15	1	Y	10
P18	Reservation	Reservation	Reservation	Reservation	Reservation
P19	Speed smoothness	0—10	1	N	0
P20	User-defined Micro Steps	4—1000	50	Y	8
P21	Close motor to detect the lack of Phase	0—1	1	N	0
P22	Power on display	0—4	1	Y	0

There are total 23 parameter configurations, use the HISU to download the configured parameters to the drive, the detail descriptions to every parameter configuration are as follows:

Item	Description
Reset	Writing “11” will reset the drive.
Current loop Kp	Kp is adjusted to make current rise fast or not. Proportional Gain determines the response of the drive to setting command. Low Proportional Gain provides a stable system (doesn’t oscillate), has low stiffness, and the current error, causing poor performances in tracking

	current setting command in each step. But too large proportional gain values may cause oscillations and unstable system.
Current loop Ki	The Ki is adjusted to reduce the steady error. Gain Integral helps to overcome the static current error of the drive. A low or zero value for Integral Gain may have current errors at rest. Increasing the integral gain can reduce the error. But if the Integral Gain is too large, the system may “hunt” (oscillate) around the desired position.
Damping coefficient	This parameter is used to change the damping coefficient in case of the desired operating state is under resonance frequency.
Position loop Kp	The PI parameters of the position loop. The default values are suitable for most of the application, you don’t need to change them. Contact us if you have any question.
Position loop Ki	
Speed loop Kp	The PI parameters of the speed loop. The default values are suitable for most of the application, you don’t need to change them. Contact us if you have any question.
Speed loop Ki	
Open loop current	This parameter affects the static torque of the motor.
Close loop current	This parameter affects the dynamic torque of the motor. (The actual current = open loop current + close loop current)
Alarm Control	This parameter is set to control the Alarm optocoupler output transistor. 0 means the transistor is cut off when the system is in normal working, but when it comes to fault of the drive, the transistor becomes conductive. 1 means opposite to 0.
Stop lock enable	This parameter is set to enable the stop clock of the drive. 1 means enable this function while 0 means disable it.
Enable Control	This parameter is set to control the Enable input signal level, 0 means low, while 1 means high.

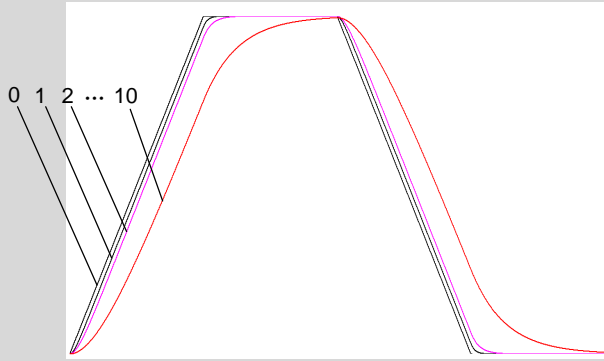
<p>Arrival Control</p>	<p>This parameter is set to control the Arrival optocoupler output transistor. 0 means the transistor is cut off when the drive satisfies the arrival command, but when it comes to not, the transistor becomes conductive. 1 means opposite to 0.</p>																																				
<p>Encoder resolution</p>	<p>This drive provides two choices of the number of lines of the encoder. 0 means 1000 lines, while 1 means 2500 lines.</p>																																				
<p>Position error limit</p>	<p>The limit of the position following error. When the actual position error exceeds this value, the drive will go into error mode and the fault output will be activated. (The actual value = the set value × 10)</p>																																				
<p>Pulses/Revolution</p>	<table border="1"> <tr> <td>Para</td> <td>0</td> <td>1</td> <td>2</td> <td>3</td> <td>4</td> <td>5</td> <td>6</td> <td>7</td> </tr> <tr> <td>Pulses/Rev</td> <td>User-defined</td> <td>800</td> <td>1600</td> <td>3200</td> <td>6400</td> <td>12800</td> <td>25600</td> <td>51200</td> </tr> <tr> <td>Para</td> <td>8</td> <td>9</td> <td>10</td> <td>11</td> <td>12</td> <td>13</td> <td>14</td> <td>15</td> </tr> <tr> <td>Pulses/Rev</td> <td>1000</td> <td>2000</td> <td>4000</td> <td>5000</td> <td>8000</td> <td>10000</td> <td>20000</td> <td>40000</td> </tr> </table>	Para	0	1	2	3	4	5	6	7	Pulses/Rev	User-defined	800	1600	3200	6400	12800	25600	51200	Para	8	9	10	11	12	13	14	15	Pulses/Rev	1000	2000	4000	5000	8000	10000	20000	40000
Para	0	1	2	3	4	5	6	7																													
Pulses/Rev	User-defined	800	1600	3200	6400	12800	25600	51200																													
Para	8	9	10	11	12	13	14	15																													
Pulses/Rev	1000	2000	4000	5000	8000	10000	20000	40000																													
<p>Speed smoothness</p>	<p>This parameter is set to control the smoothness of the speed of the motor while acceleration or deceleration, the larger the value, the smoother the speed in acceleration or deceleration.</p> 																																				
<p>User-defined p/r</p>	<p>User can set the micro steps according the specific situation, the actual micro steps = the set value × 50.</p>																																				

Close motor to detect the lack of Phase Power on display	Parameter	0	1	2	3	4	
	Data display	Speed reference	Speed feedback	Position Tracking error	Position reference	Position feedback	

1 is closed, and 0 is not closed. The use of manufacturer factory maintenance.

Remark:

- ① Switch to parameter configuration Mode via ‘M’
- ② Switch to parameter you want to configure via ‘◀’; You can also know the number which is configuring according to the left 7-segment display, for example: the display ‘1’ indicates you are configuring the first number on the right; Then change the parameter via ‘▼’ or ‘▲’, Change the value from big to small circularly via ‘▼’, for example :”9, 8... 1, 9”; Adjust the opposite value via ‘▲’;
- ③ Save the set parameter via ‘ENT’ when it is set correctly according to your adjustment; repeal the parameter to the original value via ‘M’, then return.

(**Attention:** The button ‘▲’ may come to invalid when the set value comes to the maximum; Press the button ‘◀’ to select the most significant digit when there is only this digit, decrease this value via ‘▼’, and in this way can change the most significant value, for example the maximum value is 100, so when it comes to 100, you have to choose the most significant digit and then to decrease it into 0, this is the only way to

reconfigure this value .)

10. Parameter adjustment method

10.1 Button Panel Operation

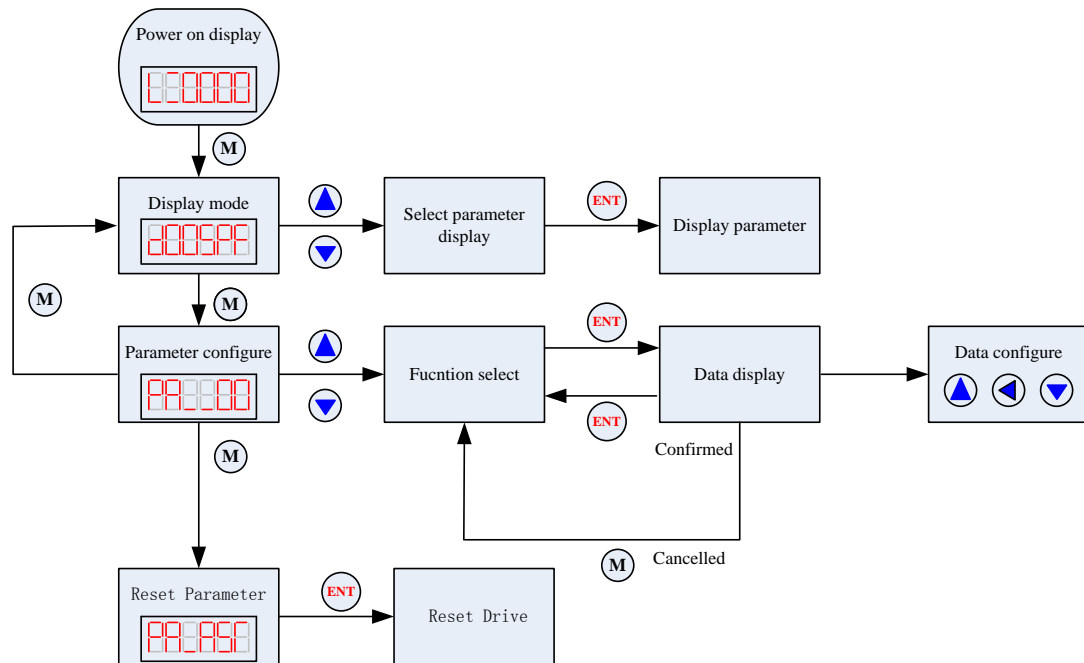

Fig. 7 Button operation flow diagram

10.2 Mode Configure Operation Example

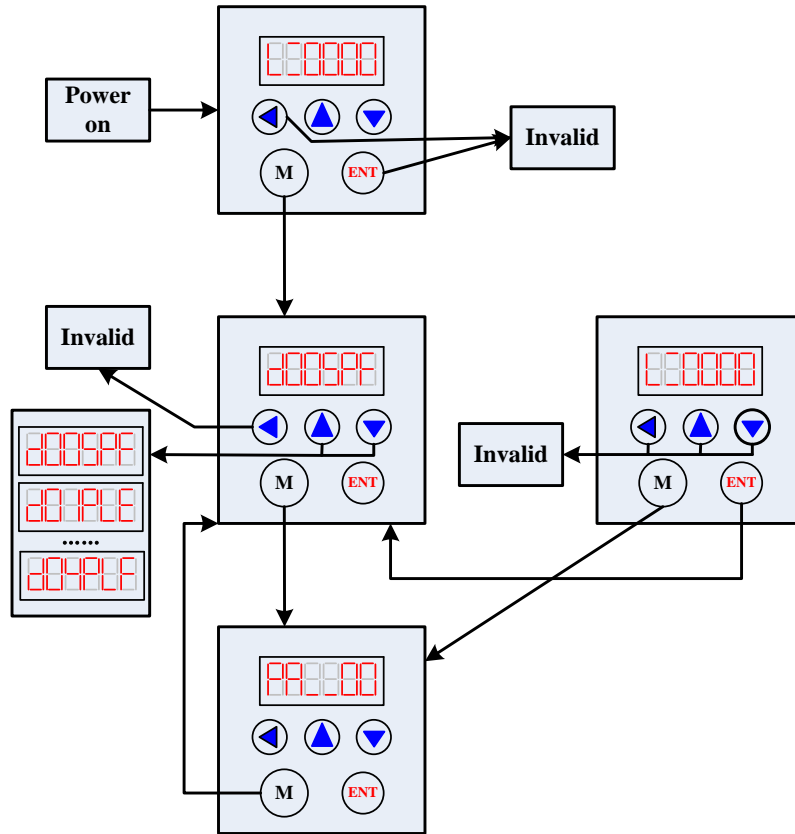

Fig. 8 Display operation flow diagram

10.3 Parameter Configure Operation Example

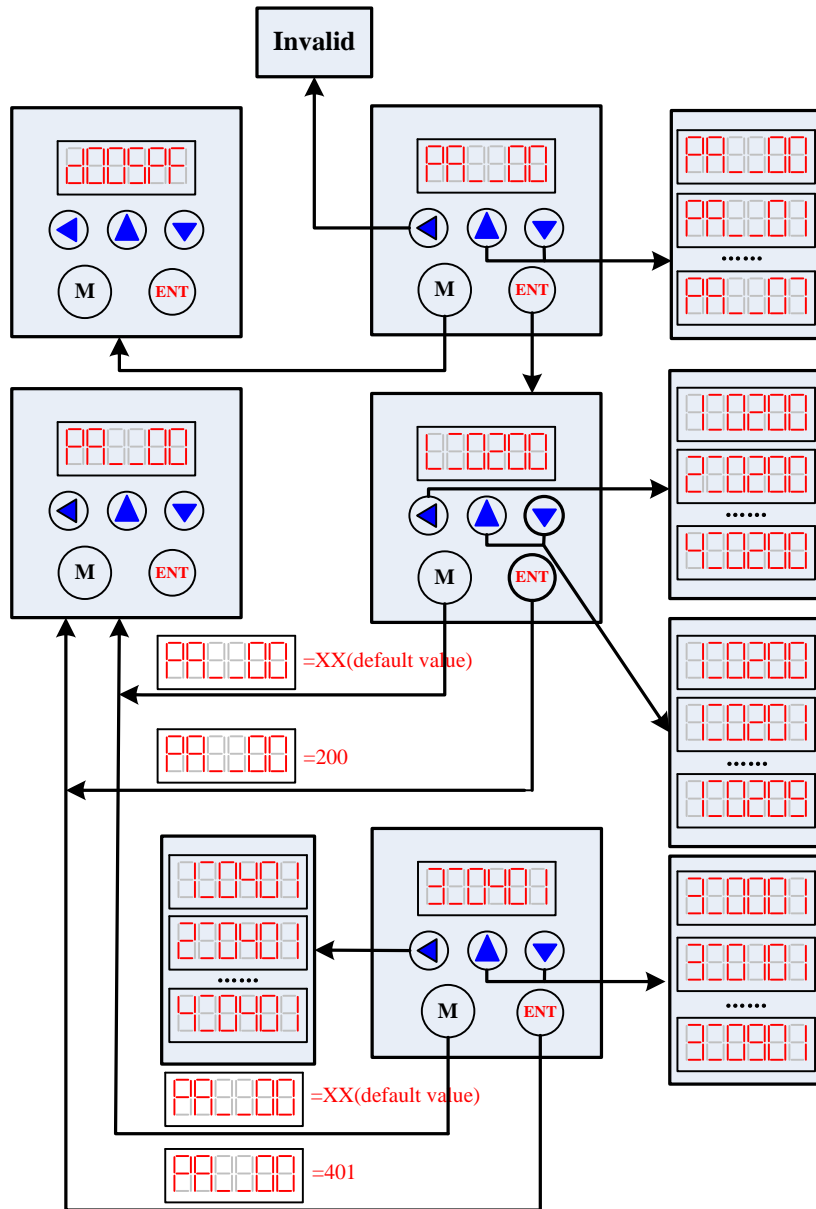

Fig. 9 Parameter configure flow diagram

Attention: The default parameters of current loop, position loop and speed loop are almost the best, user no need to change them, but to configure the parameter Pulses/revolution according to the necessity of the control system.

11. Typical Connections to 3HSS2208H-86

The typical connections to 3HSS2208H-86 are shown in figure 10. The power source grade AC180V ~ AC250V selection is based on the

matching motor.

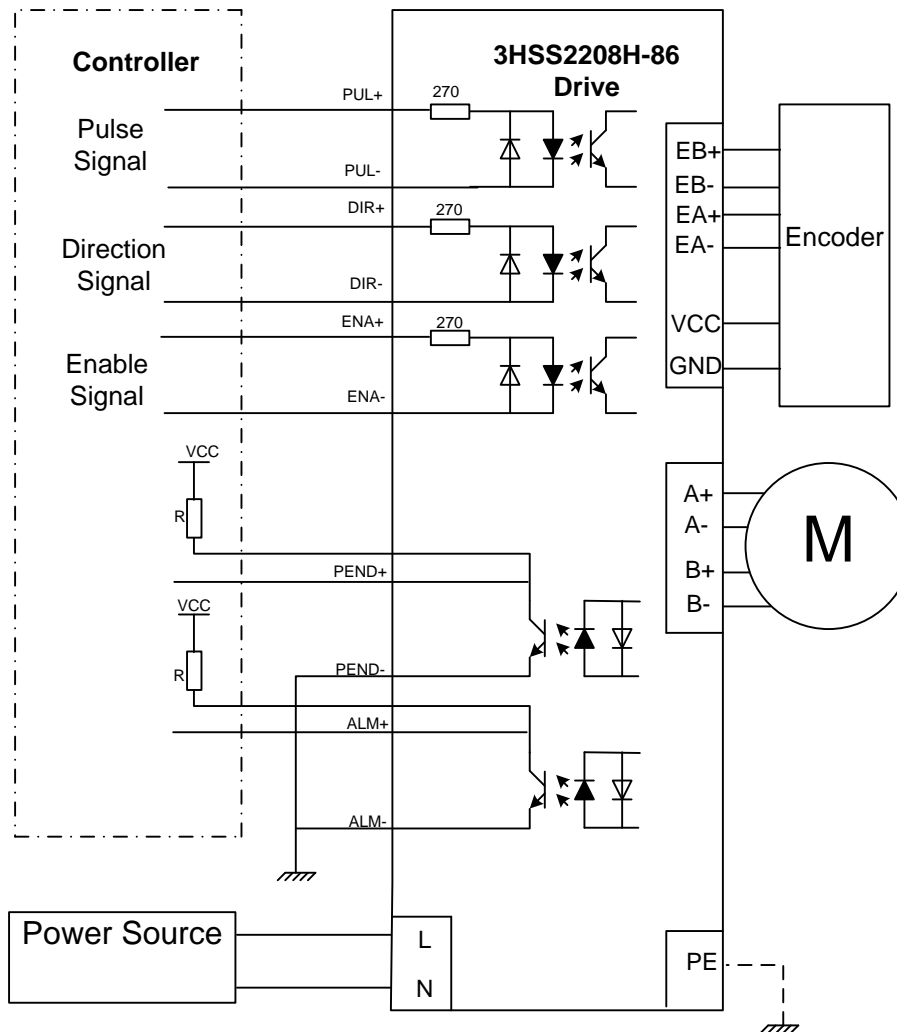

Fig. 10 Typical connections to 3HSS2208H-86

Attention : R (3~5K) must be connected to control signal terminal.

12. Processing Methods to Common Problems and Faults

12.1 Power on but no digital tube display

- No power input, please check the power supply circuit. The voltage is too low.

12.2 Power on or after the motor running a small angle and fault data display

- Please check the motor feedback signal and if the motor is connected with the drive.

- The stepper servo drive is over voltage or under voltage. Please lower or increase the input voltage.
- Please check the motor phase wires if they are connected correctly, if not, please refer to the 4.1.2 and 4.1.3 Power Ports.
- Please check the parameter in the drive if the poles of the motor and the encoder lines are corresponding with the real parameters, if not, set them correctly.
- Please check if the frequency of the pulse signal is too fast, thus the motor may be out of its rated speed, and lead to position error.

12.3 After input pulse signal but the motor not running

- Please check the input pulse signal wires are connected in reliable way.
- Please make sure the input pulse mode is corresponding with the real input mode.
- Whether the motor enable is on.